

SUSPENDED PARTITION AND FOLDABLE WALLS

# TKV ALL-GLASS FOLDING WALL

Folding walls have a top rail and consist of glass panels connected via hinges, which are folded and stored at the end of the rail when the wall opens  
The roller is in the middle of the panel  
Each panel of the folding wall is equipped with a recessed fixing device to lock the panels into the floor



Width\*\*

Max 5000 mm

Height\*\*

Max 3500 mm

PANEL WIDTH\*\*

Max 900 mm  
(SIZE DEPENDS ON THE WEIGHT: VER 1 – MAX 70 KG VER 2 – MAX 90 KG)

RAIL DEPTH

113 mm

DEPTH MODULE

35 mm

PROFILE MATERIAL

Aluminium

FINISH FOR RAIL AND PANEL PROFILES \*

Natural anodisation, paint (RAL)

PANEL FILLING MATERIAL

10–12 mm tempered glass

LOCK CASE\*\*

Floor lock

PULL HANDLES

According to the design

FOLDING WALL IS AVAILABLE:

VER 1: The door section is attached to the moving part of the folding wall and moves along with the folding section to the parking position  
The door cannot be opened in two direction  
The hinge does not have a closing mechanism

VER 2: The door is stand-alone, opens in both directions and comes with an optional latch  
The foldable section does not include a door function  
The door does not move along with the folding section to the parking position

EXTRAS

Laminated, tinted glass

\*Custom finishes available upon agreement

\*\*Custom solutions upon agreement

VER 1

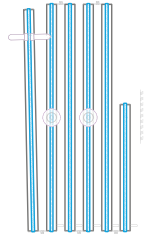
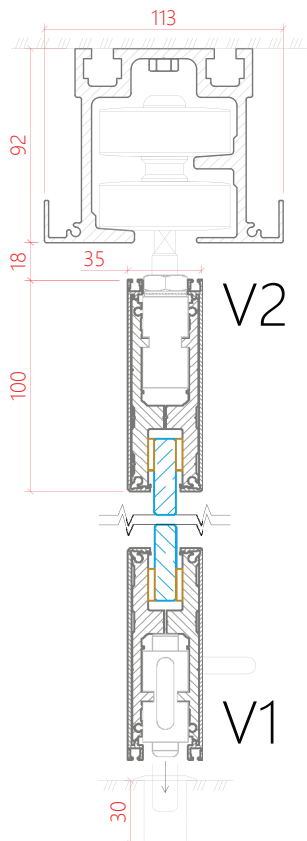
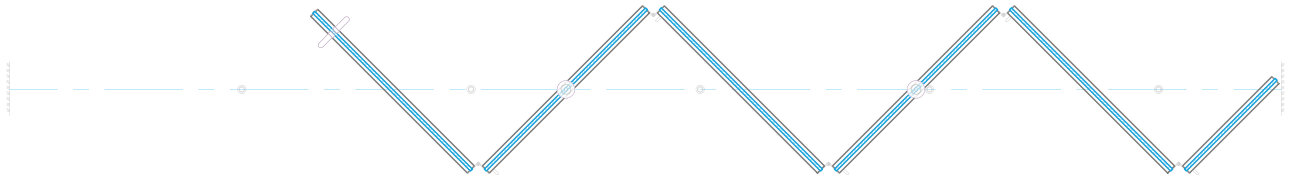
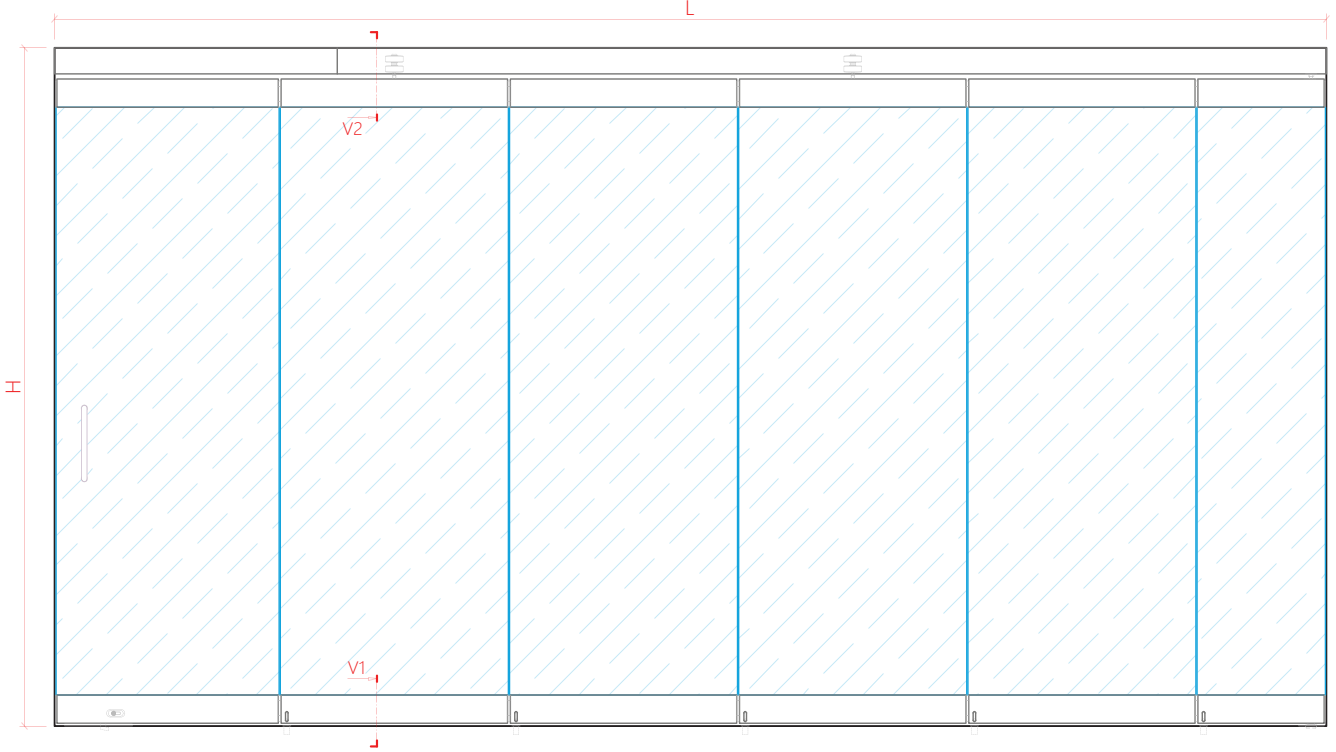

VER 2

